



Self contained luminaire

Levanti

IP65 Surface mounted luminaire

Product Description

A superb partnership of die cast aluminium and impact resistant polycarbonate, this high quality IP65 architectural luminaire utilises energy efficient TC-L Compact Fluorescent and provides a combination of direct illumination and a coloured back light halo.

The Levanti is of the very highest standard and is eminently suited to design led projects. Three versions are available, white, green or blue back light.

The stylish housing contains energy efficient high frequency control gear and there are emergency versions as well.

Product Features

- Visually pleasing appearance
- Attractive back light option – three colours available white – blue - green
- Vandal resistant with a locking die cast aluminium bezel
- Mains and emergency versions available

Applications

- Prestigious offices
- Hotels
- Restaurants
- Reception areas
- Stairwells



Levanti

IP65 Surface mounted luminaire

Dimensions

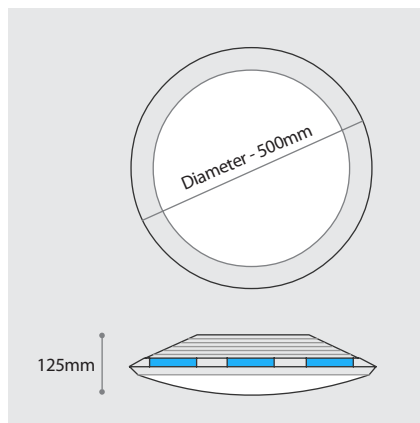

Finishes

WHO - White Halo
BLO - Blue Halo
GRO - Green Halo

Emergency Options

AT - Auto test function
CT - Central test function
CB - Central battery slave unit

Order Codes

Order Code	Wattage	Lamp Type	Control Gear
EZL500/218/*	2 x 18	TC-L Compact Fluorescent	High Frequency
EZL500/218/M3*	2 x 18	TC-L Compact Fluorescent - one lamp in maintained emergency mode	High Frequency with 3 hour emergency function

* Add suffix for option and finish

EG. EZL500/226/M3/BLO - 1x28 Watt 2D Torlono pendant luminaire with a maintained emergency option blue back light and white gallery.



escapezone →

escapezone Ltd

Unit 23, Red Lion Business Centre
Red Lion Road, Surbiton, Surrey KT6 7QD
Tel: 0208 391 9001 Fax: 0208 391 9002
Email: sales@escapezone.net
Web: www.escapezone.net