



Self contained luminaire

Busalla

Pendant mounted luminaire

Product Description

This stylish circular pendant luminaire has an opal impact resistant polycarbonate diffuser which reduces glare and provides an even visual level of illumination.

High efficiency 2D compact fluorescent lamps are incorporated for reduced energy consumption and combined with high frequency control gear there is flicker free operation, instant start and an extended lamp life. Emergency versions are also available.

Product Features

- Energy efficient high frequency control gear as standard
- Easy lamp replacement and maintenance
- Opal impact resistant polycarbonate diffuser & spun metal gallery
- High quality sub components used for an extended service life.
- Mains & emergency versions available

Applications

- Schools
- Libraries
- Reception areas
- Leisure Centres



Busalla

Pendant mounted luminaire

Dimensions

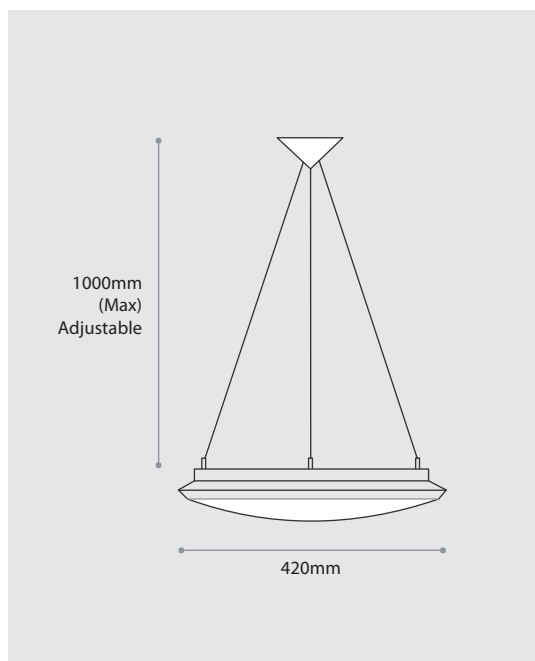

Finishes

WH - White
CH - Chrome
BR - Brass

Emergency Options

AT - Auto test function
CT - Central test function
CB - Central battery slave unit

Order Codes

Order Code	Wattage	Lamp Type	Control Gear	Weight
EZBUP420/28/*	1 x 28	2D Compact Fluorescent	High Frequency	2.9 kgs
EZBUP420/28/M3/*	1 x 28	2D Compact Fluorescent	High Frequency with a three hour maintained emergency function	3.4 kgs
EZBUP420/38/*	1 x 38	2D Compact Fluorescent	High Frequency	2.9 kgs
EZBUP420/38/M3/*	1 x 38	2D Compact Fluorescent	High Frequency with a three hour maintained emergency function	3.4 kgs

* Add suffix for option and finish

EG. EZBUP420/38/M3/BR/AT 1x38 Watt 2D Busalla pendant luminaire with a maintained emergency option, brass gallery and an auto test function.

escapezone 

escapezone Ltd
Unit 23, Red Lion Business Centre
Red Lion Road, Surbiton, Surrey KT6 7QD
Tel: 0208 391 9001 Fax: 0208 391 9002
Email: sales@escapezone.net
Web: www.escapezone.net