



Self contained luminaire

Bedonia

Pendant mounted luminaire

Product Description

This stylish pendant slim line circular luminaire with an impact resistant opal polycarbonate diffuser provides both direct and indirect illumination.

High efficiency 2D compact fluorescent lamps are incorporated providing an even level of illumination and when combined with high frequency control gear there is flicker free operation with instant start together with an extended lamp life. Emergency versions are also available.

Product Features

- Energy efficient high frequency control gear as standard
- Easy lamp replacement and maintenance
- Opal impact resistant polycarbonate diffuser & spun aluminium gallery
- High quality sub components used for an extended service life.
- Mains and emergency versions available

Applications

- Schools
- Libraries
- Reception areas
- Leisure Centres



Bedonia

Pendant mounted luminaire

Dimensions

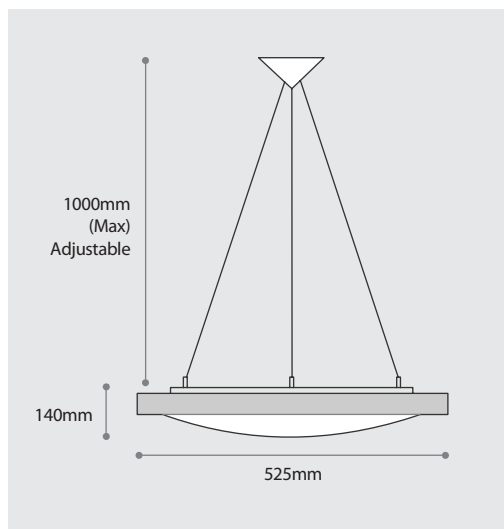

Finishes

WH - White
BL - Black
GO - Gold
BR - Brushed Aluminium

Emergency Options

AT - Auto test function
CT - Central test function
CB - Central battery slave unit

Order Codes

Order Code	Wattage	Lamp Type	Control Gear	Weight
EZBE525/28/*	1 x 28	2D Compact Fluorescent	High Frequency	2.9 kgs
EZBE525/28/M3/*	1 x 28	2D Compact Fluorescent	High Frequency with a three hour maintained emergency function	3.4 kgs
EZBE525/38/*	1 x 38	2D Compact Fluorescent	High Frequency	2.9 kgs
EZBE525/38/M3/*	1 x 38	2D Compact Fluorescent	High Frequency with a three hour maintained emergency function	3.4 kgs

* Add suffix for option and finish

EG. EZBE525/38/WH - 1x38 Watt 2D Bedonia pendant luminaire with a white gallery.

escapezone 

escapezone Ltd
Unit 23, Red Lion Business Centre
Red Lion Road, Surbiton, Surrey KT6 7QD
Tel: 0208 391 9001 Fax: 0208 391 9002
Email: sales@escapezone.net
Web: www.escapezone.net