



flexible low voltage
emergency pack

Emergiflex



20 watt



12 volts



50 & 70mm

The unique Emergiflex emergency conversion system will adapt a standard low voltage tungsten halogen downlighter to operate in an emergency mode. The installer friendly battery pack, emergency module, and transformer (if used) are designed to pass through the luminaire's cut out so eliminating the need for a costly separate access hatch.

- **Maintained (M) and non-maintained (NM) versions available to suit the requirement**
- **Compact size eliminates the need for costly access hatches**
- **The system will fit through the luminaire cut out for speedy installation**
- **Flame retardant flexible battery housing for maximum safety**
- **Deep discharge protection as standard to protect the service life of the battery**
- **Green LED charge indicator with one metre of lead for remote mounting or for fixing within the luminaire bezel**
- **Cool running solid state constant current charger**
- **Compact high capacity batteries**
- **Three hour duration in the event of a mains failure**



Emergiflex

flexible low voltage emergency pack

20 watt 12 volts 50 & 70mm

Types

- **Non-Maintained** – The downlight will operate in the event of a mains failure
- **Maintained** – The downlight will switch and operate normally and in the event of a mains failure

Specification

- **Power consumption:** 25Va
- **Supply voltage:** 230 ± 10% 50/60 Hz
- **Charger:** Automatic, current limited, constant voltage
- **Battery type:** Ni-Cd Nickel cadmium/VRLA valve regulated lead acid gel batteries
- **Recharge Period:** 24 hours
- **Charge indicator:** Green LED
- **Construction:** Charger – self extinguishing impact resistant polycarbonate
- **Batteries:** 1 hour fire rated indecent (flame retardant) enclosure

Standards

Designed and manufactured to:
BS EN 60598.2.22, BS EN 60-924/5,
BS EN 55015, BS EN 61547 and
BEN 61000-3-2

Wiring Diagram

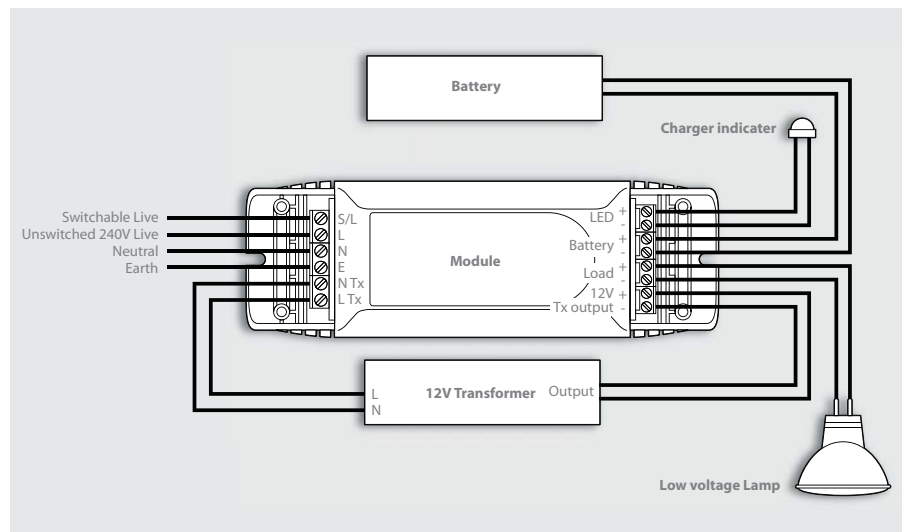

Module Dimensions

Part No.	Length	Width	Height	Weight
M1	150mm	49mm	49mm	0.3 Kg



M1

Battery Dimensions

Part No.	Length	Width	Height	Weight
B1A	625mm	32mm	38mm	1.3 Kg
B2	625mm	32mm	38mm	1.3 Kg



B1A



B2

Installation Requirements

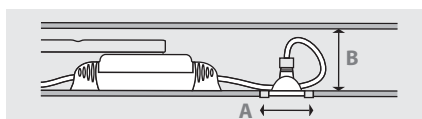

Accessories

EZ/LH, Remote LED housing



Order Codes

Cut Out Size - A	Part Number	Mode	Lamp	Min Ceiling void (B)	BLF	Ambient	Weight	Charger Type	Battery Style	Battery Rating & Type
50mm	EZS50/6/20/M3	M*	12v 20w	100mm	8%	50° C	1.6 Kg	M1	B1A	6V 13AH (Ni-Cd)
50mm	EZS50/6/20/NM3	NM	12v 20w	100mm	8%	50° C	1.9 Kg	M1	B1A	6V 13AH (Ni-Cd)
70mm	EZS70/12/20/M3	M*	12v 20	120mm	100%	25° C	3.3 Kg	M1	B2	12V 6.3AH (VRLA)
70mm	EZS70/12/20/NM3	NM	12v 20w	120mm	100%	25° C	3.6 Kg	M1	B2	12V 6.3AH (VRLA)

*Maintained version supplied with a dimmable electronic transformer.

escapezone

escapezone Ltd
Unit 23, Red Lion Business Centre
Red Lion Road, Surbiton, Surrey KT6 7QD
Tel: 0208 391 9001 Fax: 0208 391 9002
Email: sales@escapezone.net
Web: www.escapezone.net