



flexible low voltage
emergency pack

Emergiflex



100 watt



12 volts



120mm

Product Description

The unique Emergiflex emergency conversion system will adapt a standard low voltage tungsten halogen downlighter to operate in an emergency mode. The installer friendly battery pack, emergency module, and transformer (if used) are designed to pass through the luminaire's cut out so eliminating the need for a costly separate access hatch.

Product Features

- **Maintained (M) and non-maintained (NM) versions available to suit the requirement.**
- **Compact size eliminates the need for costly access hatches.**
- **The system will fit through the luminaire cut out for speedy installation.**
- **Flame retardant flexible battery housing for maximum safety.**
- **Deep discharge protection as standard to protect the service life of the battery.**
- **Green LED charge indicator with one metre of lead for remote mounting or for fixing within the luminaire bezel.**
- **Cool running solid state constant current charger.**
- **High capacity VRLA valve regulated lead acid gel batteries.**
- **Three hour duration in the event of a mains failure.**



Emergiflex

flexible low voltage emergency pack

100 watt 12 volts 120mm

Types

- **Maintained** – The pack will operate the downlight in the event of a mains failure only.
- **Non Maintained** – The pack will operate the downlight in normal and emergency mode and is complete with transformer.

Specification

- **Power consumption:** 25Va
- **Supply voltage:** 230 ± 10% 50/60 Hz
- **Charger:** Automatic, current limited, constant voltage
- **Battery type:** VRLA valve regulated lead acid gel batteries
- **Recharge Period:** 24 hours
- **Charge indicator:** Green LED
- **Construction:** Charger – self extinguishing impact resistant polycarbonate
- **Batteries:** 1 hour fire rated indecent (flame retardant) enclosure

Wiring Diagram

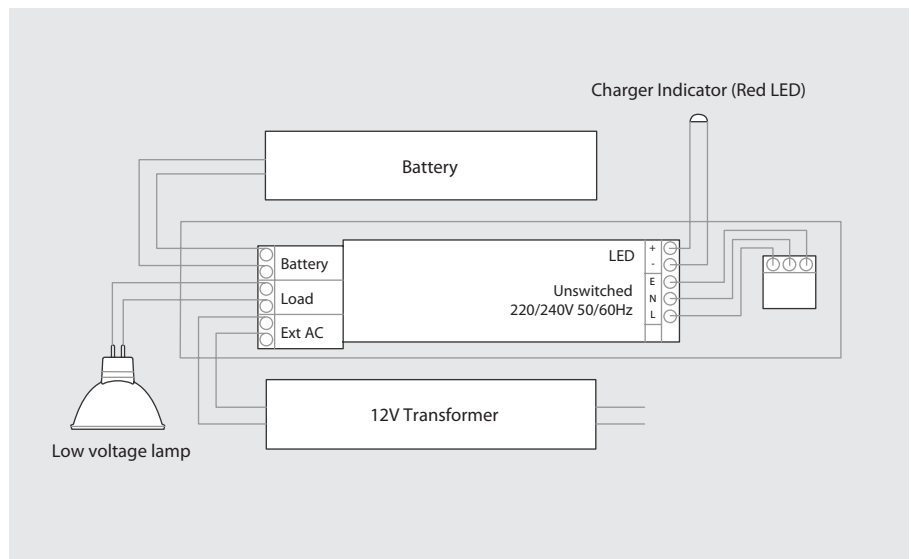

Standards

Designed and manufactured to:
BS EN 60598.2.22, BS EN 60-924/5,
BS EN 55015, BS EN 61547 and
BEN 61000-3-2

Module Dimensions

Part No.	Length	Width	Height	Weight
M2	205mm	105mm	105mm	1.6 Kg



Battery Dimensions

Part No.	Length	Width	Height	Weight
B4	395mm	67mm	100mm	5.4 Kg
B4x2	790mm	134mm	100mm	10.8 Kg



Installation Requirements

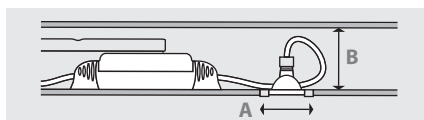

Accessories

EZ/LH, Remote LED housing



Order Codes

Cut Out Size -A	Part Number	Mode	Lamp	Min Ceiling void (B)	BLF	Ambient	Weight	Charger Type	Battery Style	Battery Rating & Type
120mm	EZS120/12/100/M3	M*	12v 100w	155mm	100%	25° C	12.5 Kg	M2	B4 x 2	12V 28AH (VRLA)
120mm	EZS120/12/100/NM3	NM	12v 100w	155mm	100%	25° C	13 Kg	M2	B4 x 2	12V 28AH (VRLA)
120mm	#EZS120/12/100SP/M3	M*	12v 100w	155mm	100%	25° C	7 Kg	M2	B4	12V 28AH (VRLA)
120mm	#EZS120/12/100SP/NM3	NM	12v 100w	155mm	100%	25° C	7.3 Kg	M2	B4	12V 28AH (VRLA)

*Maintained version supplied with a dimmable electronic transformer. # Special application 1 hour rated.

escapezone

escapezone Ltd
Unit 23, Red Lion Business Centre
Red Lion Road, Surbiton, Surrey KT6 7QD
Tel: 0208 391 9001 Fax: 0208 391 9002
Email: sales@escapezone.net
Web: www.escapezone.net