



Life-Line

surface emergency
exit sign – LED
illuminated

Viewing Distance

25 Metres

Product Description

A surface mounted LED emergency exit display luminaire has been designed for use in locations where both style and quality are paramount. The modern clean lines blend into both traditional and contemporary interiors with a choice of finishes to suit.

The use of high efficiency LED technology combined with small high capacity batteries and miniaturised control circuitry assures an ultra-slim appearance.

Maintenance costs are reduced as LED lamp life is up to 80,000 hours and this light source is significantly more efficient than those used in conventional signs utilising an 8 watt T5 fluorescent tubes so reducing energy costs.

Product Features

- Latest LED lamp technology assures a compact stylish design and even
- Up to 80,000 hours lamp life reduces maintenance costs
- Low power consumption reduces running costs
- First fix mounting plate for ease of installation
- Integral control gear mounted on a base plate for ease of maintenance
- 10mm thick screen printed edge lit legends for a quality appearance
- Wide choice of finishes to suit the application
- Three hour emergency duration in the event of a mains failure



Life-Line

Viewing Distance

surface emergency exit sign – LED illuminated

25 Metres

Dimensions

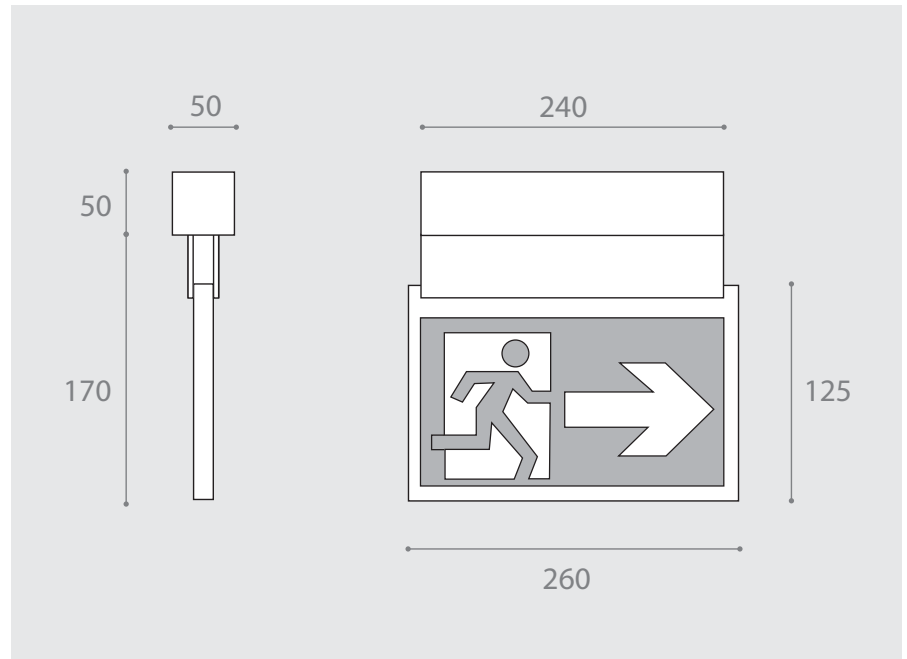

Installation

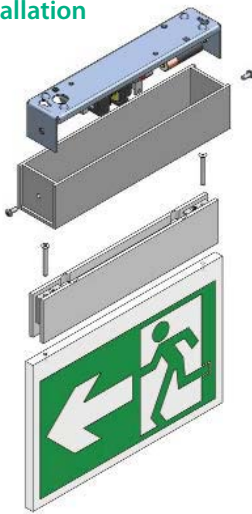

- Separate base plate for ease of mechanical installation
- Module and terminals are on the base plate for simple electrical connection
- Sign and body can be retrospectively fitted prior to occupation so preventing damage

Luminaire - Part Numbers

Illuminated	Weight	Light Source	Mode	Duration
EZK/S/240/M/*	2.2 kg	LED	Maintained	3 Hours
EZK/S/240/NM/*	2.2 kg	LED	Non-Maintained	3 Hours
Non-illuminated	Weight	* Add finish code i.e. EZK/S/240/M/W for a maintained Mini surface in white.		
EZK/SN/240/*	1.2 kg			

Legend Table - Part Numbers

Legend Size Width x Drop (mm)	Single Sided			Double Sided	
	Arrow Down	Arrow Left	Arrow Right	Arrow Down	Arrow Left/Right*
260 x 125	EZK/125/SD	EZK/125/SL	EZK/125/SR	EZK/125/DD	EZK/125/DLR

Finishes

W White RAL9010	B Black RAL9005	S Silver RAL9006	C Polished Chrome	BR Polished Brass	SN Satin Nickel
---------------------------	---------------------------	----------------------------	-----------------------------	-----------------------------	---------------------------

Viewing Distance Information

The relationship between the size of the sign and viewing distance to an observer is defined by EN 1838 (BS5266 Part 7: 1999). For a given legend height the maximum viewing distance is calculated by the formula:

$D_{max} = h \times 200m$
(for internal illuminated signs)
D = viewing distance
H = pictogram legend height

Legend size Width x Drop (millimetres)	Viewing Distance (metres)
160 x 250	23
260 x 125	25
250 x 160	32
385 x 210	43

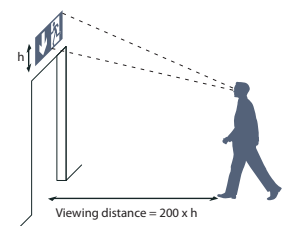

escapezone

escapezone Ltd

Unit 23, Red Lion Business Centre
Red Lion Road, Surbiton, Surrey KT6 7QD
Tel: 0208 391 9001 Fax: 0208 391 9002
Email: sales@escapezone.net
Web: www.escapezone.net